

# FTI-STK1: Vehicle Coverage and Preparation Notes

| Make              | Model                            | Year    | Install | CAN    | IMMO      | BCM | Clutch | I/O Changes             |
|-------------------|----------------------------------|---------|---------|--------|-----------|-----|--------|-------------------------|
| DL-SUB9<br>Subaru | Crosstrek STD KEY AT<br>(Canada) | 2018-23 | Type 2  | 40-Pin | Type<br>B | DSD | N/A    | Green White/Blue<br>N/A |

**Covered vehicle** use **BLADE-AL-SUB9** firmware and the following required accessories, Weblink Hub & ACC RFID1. Flash module, and update the controller firmware. **Please follow the directions for RFID programming before attempting to program the BLADE module to the vehicle.**

**CAN:** Type 2 CAN connections are made using the 40-Pin BCM connector and require connecting the white 2-pin female connector to the black male 2-pin connector at marker [D] of the illustration.

**Immobilizer:** Type B IMMO requires connecting the black and white 2-pin connectors at marker [C] of the illustration.

**Lights:** Parking lights are pre-wired in the FTI-STK1 harness. Replace the green/white wire of the CM I/O connector with the pre-terminated green/white wire of the harness.

**ACC-RFID1 (REQUIRED):** SUB9 firmware does not provide immobilizer data, an ACC-RFID1 is therefore required for remote start

**2nd START:** The FTI-STK1 harness is pre-wired with a red/white 2nd START output (not required in TYPE 2), cut and insulate the provided wire to prevent short circuits when not used.

**I/O Changes: None required**

**Advisory 1: Program ACC-RFID1 before attempting to program the BLADE module to the vehicle.**

**Advisory 2: Secure all 2-pin connections, both used and unused, to the main harness body.**

## FTI-STK1: Installation and Configuration Notes

- A** REQUIRED ACCESSORY
- B** ADAPTER NOT REQUIRED
- C** REQUIRED CONFIGURATION (TYPE B IMMO)
- D** REQUIRED CONNECTION
- E** NO CONNECTION



| FEATURE COVERAGE |               |                  |           |             |                 |                     |             |             |              |              |                |                                  |                                |                |  |
|------------------|---------------|------------------|-----------|-------------|-----------------|---------------------|-------------|-------------|--------------|--------------|----------------|----------------------------------|--------------------------------|----------------|--|
| IMMOBILIZER DATA | ARM OEM ALARM | DISARM OEM ALARM | DOOR LOCK | DOOR UNLOCK | PRIORITY UNLOCK | TRUNK/HATCH RELEASE | TACH OUTPUT | DOOR STATUS | TRUNK STATUS | BRAKE STATUS | E-BRAKE STATUS | A/M ALRM CONTROL FROM OEM REMOTE | A/M RS CONTROL FROM OEM REMOTE | AUTOLIGHT CTRL |  |

•FT-DAS Required for manual transmission.  
•BOTH Red & Red/White MUST be connected with high current application.

**Jumper Setting**

**CM7000/7200** **Cut loop for A/T**

**CM900AS/900S Jumper**

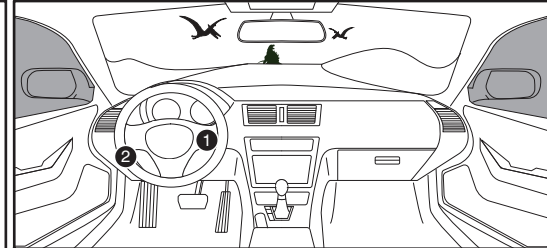
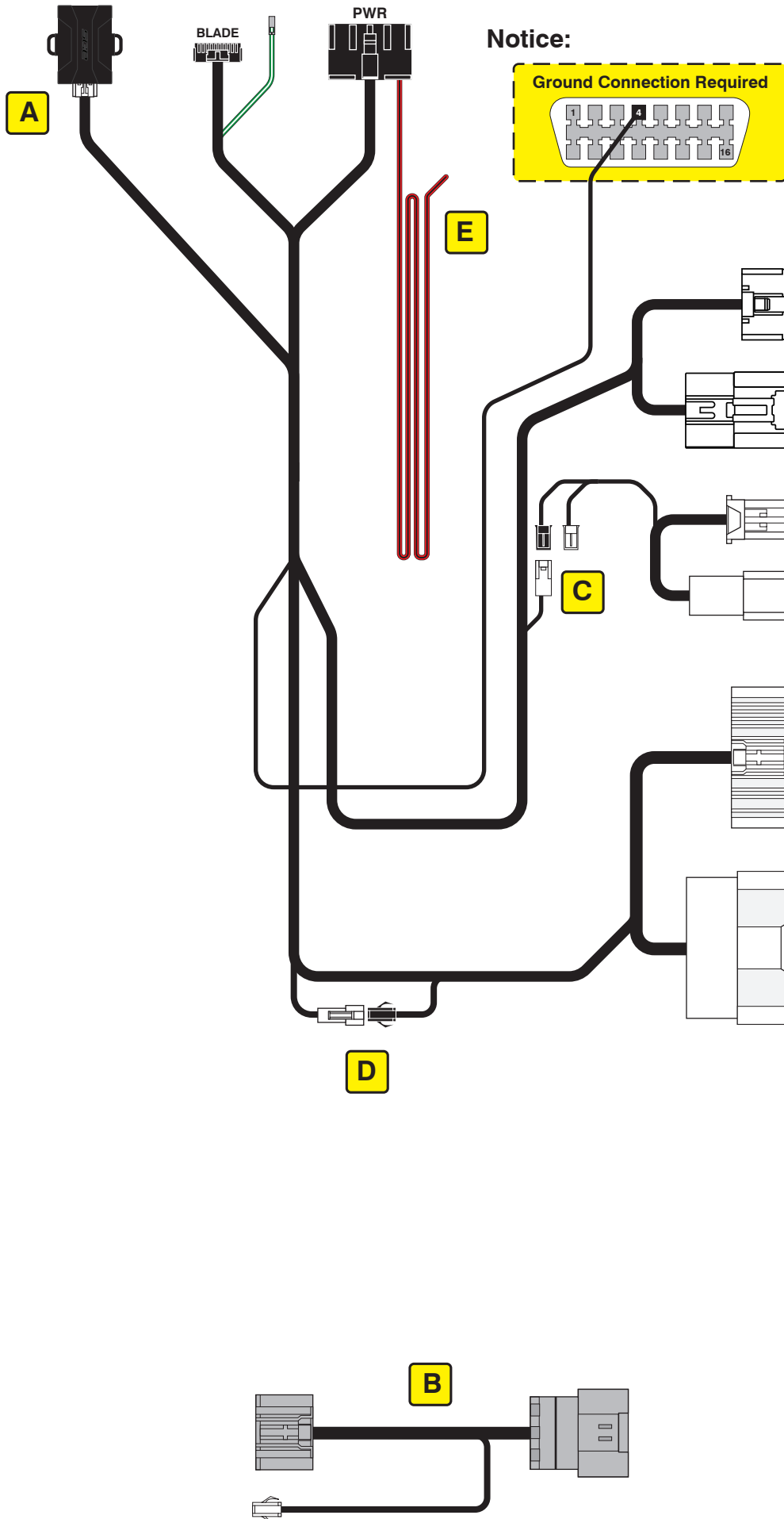

**Ignition Switch Assembly**

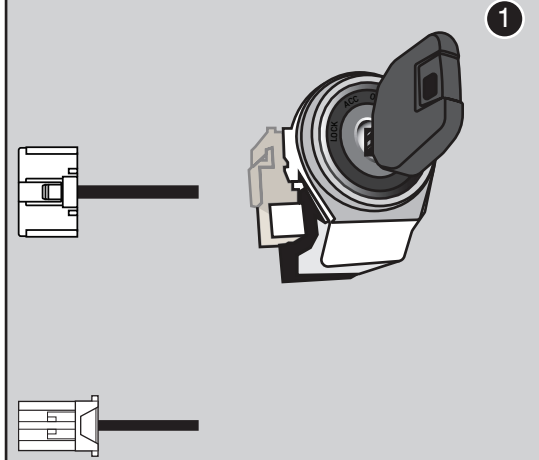

**BCM/Fuse Box**

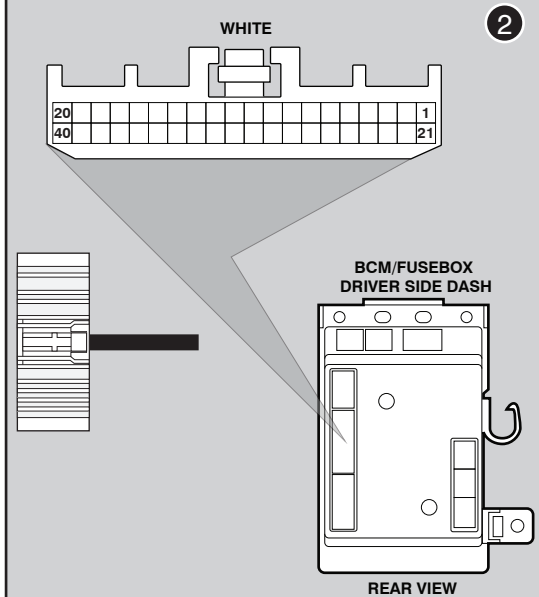

**LED Programming Error Codes**

- Module LED flashing RED during programming
- 1x RED = Unable to communicate with RFID or immobilizer data.
  - 2x RED = No CAN activity. Check the CAN wire connections.
  - 3x RED = No ignition detected. Check the ignition wire connection and CAN.
  - 4x RED = Required ignition output diode not detected.

## CARTRIDGE INSTALLATION

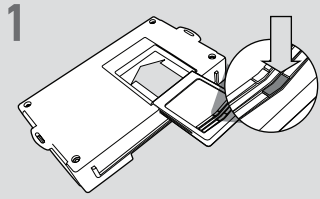

1 Slide cartridge into unit. Notice button under LED.

2

Ready for Module Programming Procedure.

## MODULE PROGRAMMING PROCEDURE



1 For this installation, the Weblink HUB is required.

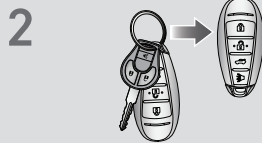

2 Remove OEM key 1 from keychain.



Place all other keyfobs at least 1 foot away from the Weblink HUB. Failure to comply may result in damage to other keyfobs or interfere with the keyfob reading process.



3 Flash the module using the Weblink HUB. Follow the on screen instructions to complete the keyfob reading process.

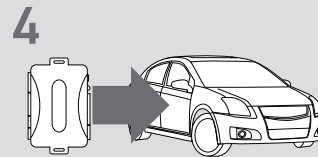

4 **WARNING:**  
Do not press the module programming button.  
Connect power first.  
Connect module to vehicle.



5 Using OEM key 1, turn key to ON position.

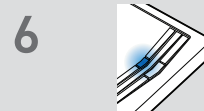

6 Wait, LED will turn solid BLUE for 2 seconds .

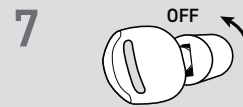

7 Turn key to OFF position.

8

Module Programming Procedure completed.