

## TROUBLESHOOTING

Wirepath structured wire modules are designed to function trouble-free. Most problems that occur are due to simple issues. If you have trouble, please check the list of simple fixes below. If the problem persists, contact your authorized SnapAV dealer or SnapAV customer service at 866.838.5052.

### No Network signal

- Verify that there is signal on the input being used from first the router and then the switch or hub.
- Check all wiring connections on output(s) with no signal including any wall-plate connections at the remote location.

### Lifetime Warranty

All Wirepath® products have a Lifetime Limited Warranty. This warranty includes parts and labor repairs on all components found to be defective in material or workmanship under normal conditions of use. This warranty shall not apply to products which have been abused, modified or disassembled. Products to be repaired under this warranty must be returned to the SnapAV or a designated service center with prior notification and an assigned return authorization number (RA).

**WIREFATH**  
STRUCTURED WIRING

### SnapAV

1800 Continental Blvd Suite 200  
Charlotte, NC 28273

704.927.7620

Tech Support: 1.866.838.5052

email: [techsupport@snapav.com](mailto:techsupport@snapav.com)

[www.snapav.com](http://www.snapav.com)

©2020 SnapAV

# WIREFATH

## STRUCTURED WIRING

## INSTALLATION GUIDE

>> WP-MOD-CAT6A-DATA8X8

### DATA MODULE

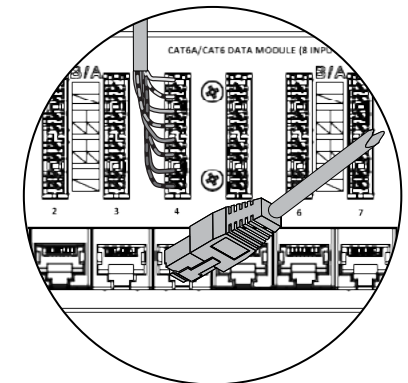
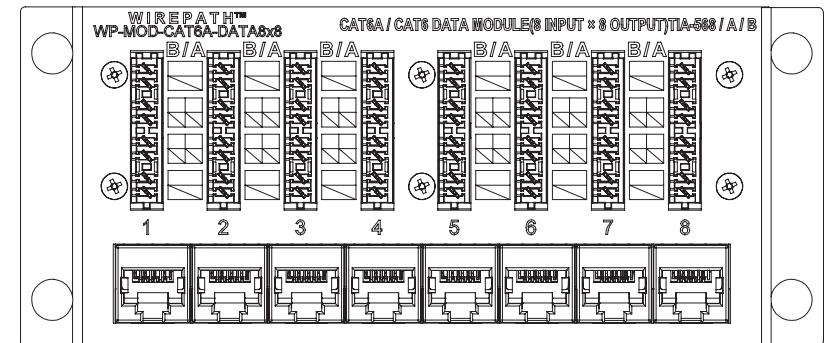

2

INTRODUCTION & FEATURES

3

INSTALLATION

4

SPECIFICATIONS

Thank you for purchasing a great item from one of the highest value lines in structured wiring available today, Wirepath. We appreciate your purchase and are committed to being the best choice for your needs.

The Wirepath WP-MOD-CAT6A-DATA8X8 is a superb choice for almost every type of home installation. It has been designed with advanced technology components that allow high performance while being flexible enough for any type of installation. Use other Wirepath structured wire items for your installation needs to get the best value possible in your systems.

### IMPORTANT INSTRUCTIONS

- Read and understand all instructions.
- Do not use this product near water, such as a bath tub, wash bowl, sink, pool or in a wet basement.
- Never install wiring for telephones during a lightning storm.
- Never touch bare telephone wires or connections unless the main line has been disconnected at the interface.
- Use caution when installing, terminating or modifying any type of wire.

### WIREFATH DATA MODULE FEATURES

#### NETWORK DISTRIBUTION FOR UP TO EIGHT LINES TO EIGHT LOCATIONS

Maximize your flexibility by using Wirepath CAT6 or CAT6A Wire.

### INSTALLATION

#### PLACING YOUR WIREFATH STRUCTURED WIRE MODULE

Wirepath structured wiring modules are designed to fit Wirepath structured wiring enclosures, but also fit most major brands of enclosures as well. Installation is simple with our familiar expansion pins. Plan the placement of each model in the enclosure based on how you have wire entering the enclosure and what will allow for the cleanest routing of wires.

If the Wirepath module is being used in an enclosure of another brand, it may be necessary to use one of the included spare mounting pins in the extra mounting flange hole and remove the two pins on that side to fit the mounting pattern of other enclosures from another brand.

#### NETWORK WIRING

A standard 110 punch down tool is all that is required to properly connect the wiring to the module. Please see illustration.

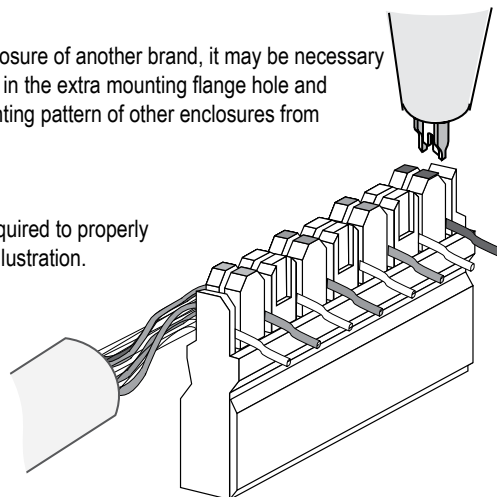

When punch down of IDC connections are complete secure the protective IDC covers over the IDC by gently pressing down until the cover clicks into place.

